

Kowan Still Worker: WP-150

The Kowan Still Worker WP-150 is 'state of the art' in effectively silent and vibration free pile pressing techniques. It can install and withdraw 400mm, 500mm and 600mm 'U' section piles with a minimum of disturbance to the surrounding environment. The Still Worker is particularly suited to installation of piles in clays of up to stiff consistency but with the assistance of water jetting and/or pre-augering can tackle most soil types. It's unique tilting mechanism enables verticality of piles to be accurately maintained.

The Still Worker operates by gripping three previously installed piles and pressing the next pile into the ground with a pressing-in force of up to 150 tonnes. Extraction of piles can also be carried out by reversing this procedure. The unit has a drawing-out force of up to 160 tonnes.

Typical noise level
at 15m – 60dBA
(Pneumatic Hammer –
105dBA)



Self Travel and Operation

1) The Still Worker is set on the reaction stand loaded with kentledge for the installation of the first two piles

2) The Still Worker moves by elevating its travel carriage whilst supporting itself on the last installed pile

3) The travel carriage then travels forward

4) The travel carriage lowers itself and drops onto the installed piles and continues its hydraulic installation process

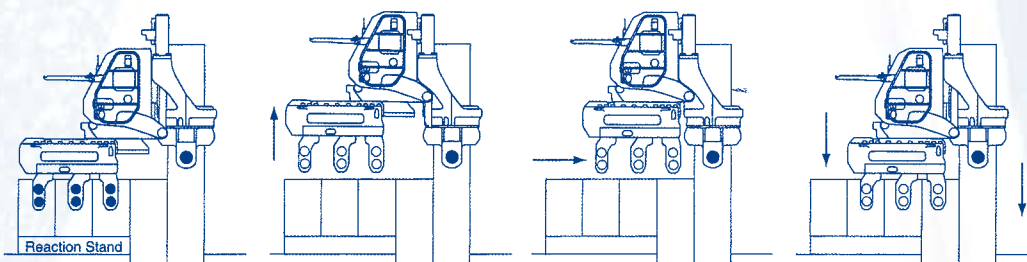

ADVANTAGES

- 'Silent'
- 'Vibration free'
- Can install piles only 750mm away from centre line to adjacent structures
- Safer, no working at height required

Kowan Still Worker: WP-150

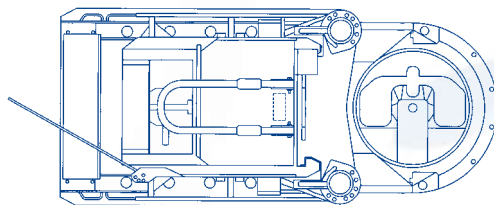
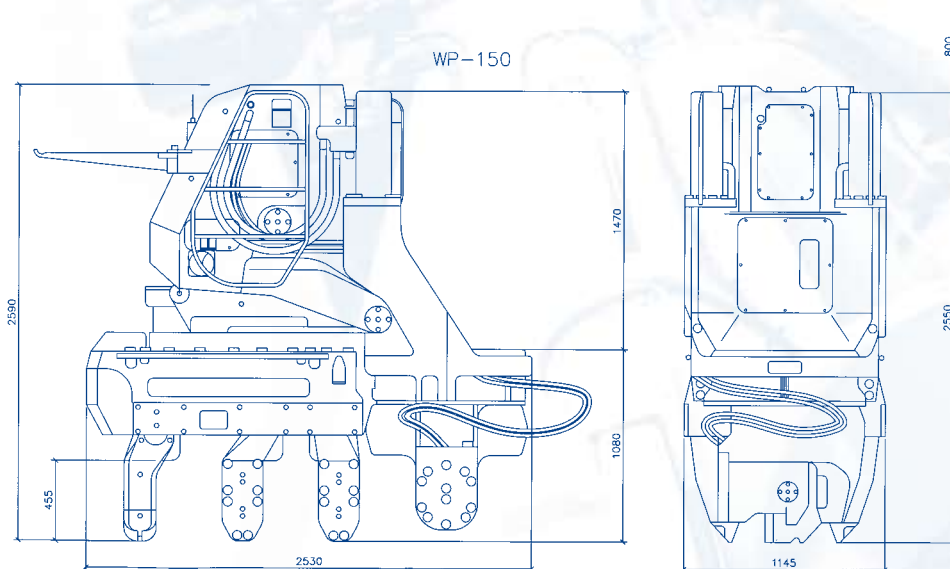

WP-150

Plan

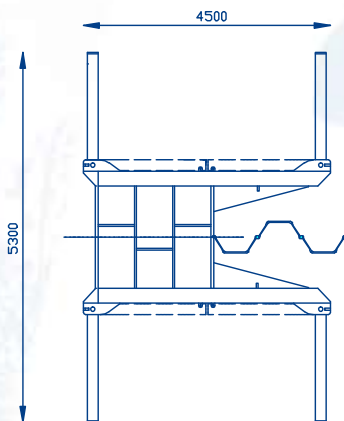

Section

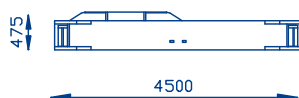

MODEL	WP-150
Moving System	Self-moving
Pressing-in Force	150 metric tons max.
Drawing-out Force	160 metric tons max.
Pressing-in Speed	1.8-20 m/min.
Drawing-out Speed	1.9-17 m/min.
Stroke	800 mm
Operation System	Wireless radio-control & cabled remote-control
Device	Tilting Device $\pm 5^\circ$
Application Sheet-piles	400/500/600 mm
Weight	Approx. 10.900 kg

HYDRAULIC UNIT	TE-200
Power	Diesel Engine
Dimensions	
Total length	4020 mm
Total width	1740 mm
Total height	1790 mm
Weight	Approx 4.700 kg
Main Power	200 ps/1800 rpm
Hydraulic Pump	Variable-capacity Piston Pump
Hydraulic Pump Pressure	350 kg/cm ² max.